

Instructions for Use of the Jaw Elevation Device (JED™)

Indications for use: The JED™ is designed to assist health care providers in maintaining an open airway in patients receiving sedation for diagnostic or therapeutic procedures.

WARRANTY:

Hypnoz Therapeutic Devices, Inc. warrants the JED™ against faulty materials or manufacturing defects for a period of ninety (90) days from the date of invoice, provided that the product is used in accordance with the procedures set forth in the instructions below. Warranty applicable only if purchased from an authorized distributor. HYPNOZ THERAPEUTIC DEVICES, INC. DISCLAIMS ALL OTHER WARRANTIES, WHETHER EXPRESS OR IMPLIED, INCLUDING, WITHOUT LIMITATION, WARRANTIES OF MERCHANTABILITY OR FITNESS FOR A PARTICULAR PURPOSE.

General guideline: The JED™ assists the provider in maintaining an open airway by flexing the neck, extending the head, and displacing the mandible anteriorly. This can be optimally accomplished by positioning the patient's head on the head support and adjusting the vertical support arms such that the center of the mandible cups cradles the angle of the mandible, while rotating the head back and advancing the mandible

1. Center the patient's head on top of the JED™ head support, aligning the patient's lips with the positioning line.

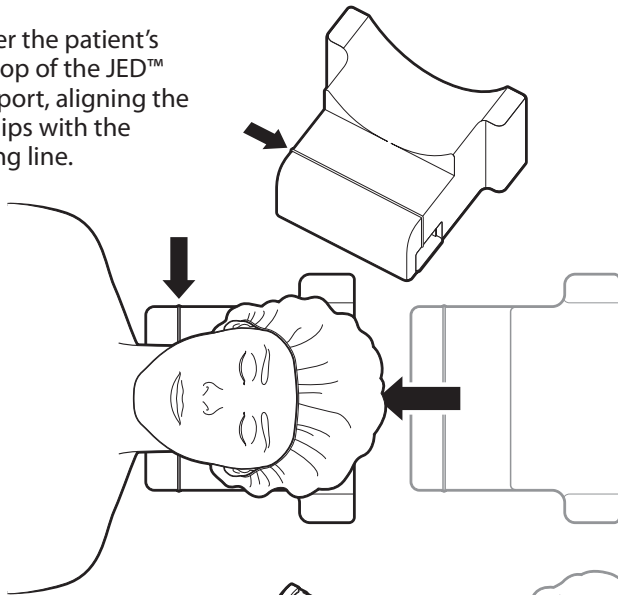

3. Slide both vertical support arms (Green for right and Red for left), with disposable mandible cups, partway into the base of the head support.

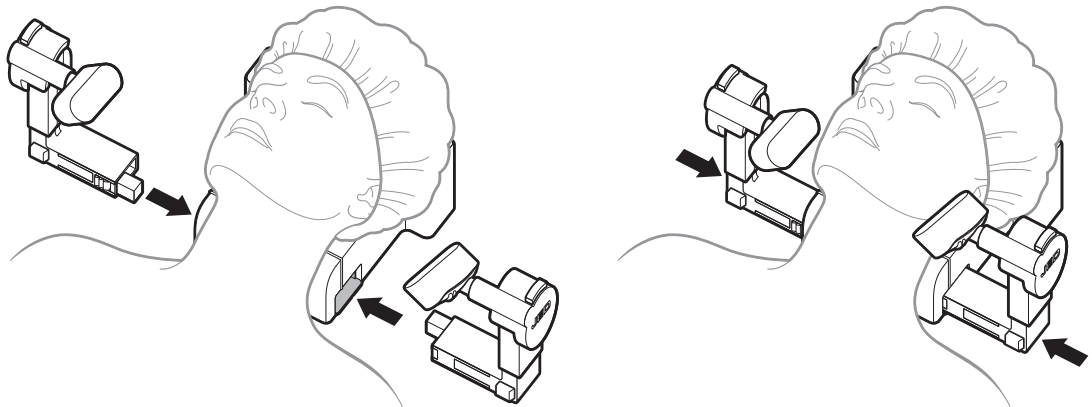

4. Simultaneously press and hold the buttons (A) on top of each of the rotating knobs to slide the vertical support arms down to their lowest position, and then turn the rotating knobs forward so that the mandible cups are in the lowest (forward) position.

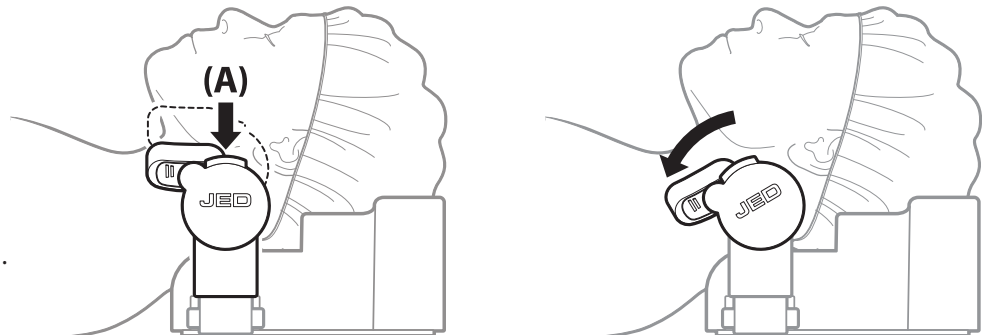

⚠ W A R N I N G S ⚠

USE OF THE JED™ DOES NOT REPLACE THE NEED FOR CONSTANT MONITORING OF THE PATIENT BY A MEDICAL PROFESSIONAL.

DO NOT USE THE JED™ IF THE PATIENT HAS AN UNSTABLE NECK, CERVICAL REDICULOPATHY, OR TEMPOROMANDIBULAR JOINT DISORDER.

FEDERAL LAW RESTRICTS THIS DEVICE TO USE BY OR ON THE ORDER OF A LICENSED HEALTH CARE PRACTITIONER.

THE REUSABLE JED™ IS TO BE USED ONLY WITH HYPNOZ DISPOSABLE MANDIBLE CUPS. DISPOSABLE MANDIBLE CUPS ARE FOR SINGLE PATIENT USE ONLY. **DO NOT REUSE.**

CLEAN THE JED™ WITH SOAP AND WATER OR AN ENZYMATIC CLEANER (E.G., EmPower®) TO REMOVE ANY STAIN OR DEBRIS. THEN DISINFECT WITH A HIGH-LEVEL DISINFECTANT (E.G., GERMICIDAL DISPOSABLE CLOTHS, Cidex®) AND ALLOW TO DRY BEFORE USE. **DO NOT SOAK IN ANY CLEANING SOLUTION.**

DO NOT PLACE ANY PART OF THE JED™ OR DISPOSABLE MANDIBLE CUPS IN AN AUTOCLAVE OR STERIS.

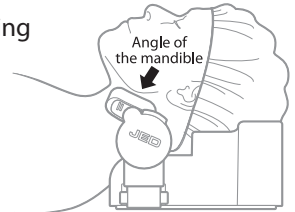

2. Place the disposable mandible cups (marked Green for right and Red for left) into the reusable vertical support arms (also marked Green for right and Red for left).

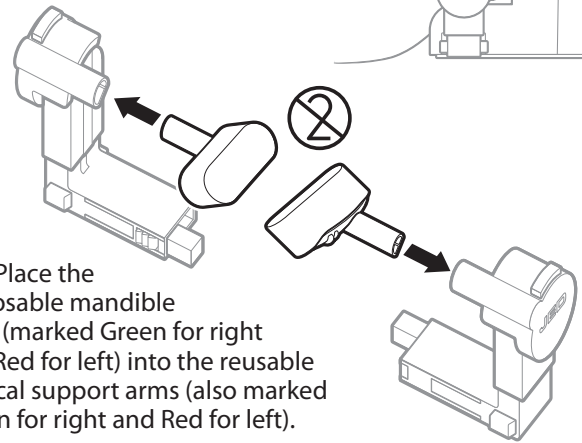

DO NOT PRESS BUTTONS (A) ON TOP OF THE ROTATING KNOBS DURING STEPS 5 – 7.

5. After administering sedation, place the patient's head in a proper sniffing position and verify adequate air exchange via chest excursion and/or expired CO² waveform. Use the left hand to hold the head position constant, then use the right hand to palpate the angle of the mandible on the right. Next, slide the vertical support arm inward towards the patient's jaw until the mandible cup is posterior to the angle of the mandible, then lift the arm up until the mandible cup firmly cradles the angle of the mandible.

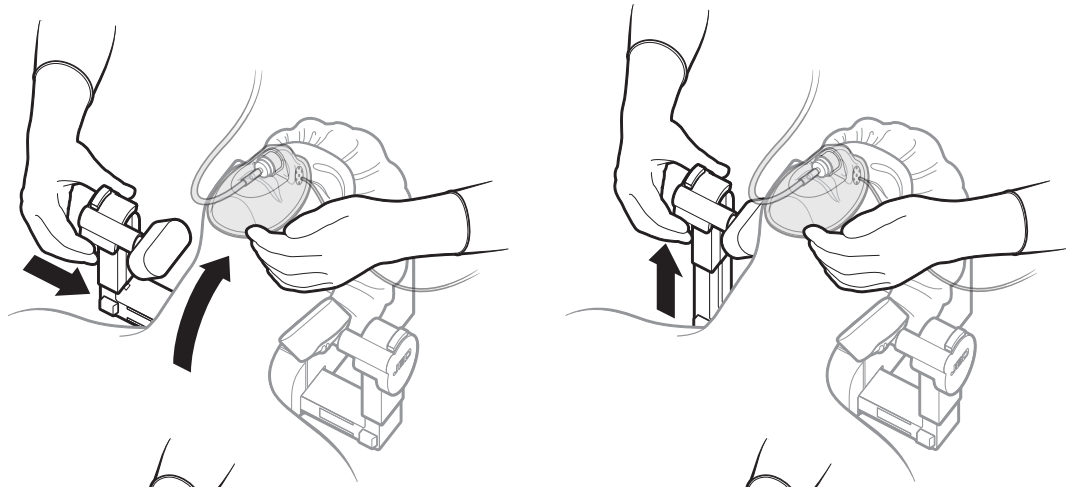

6. While maintaining the proper sniffing position, switch hands so that the right hand is now holding the head position constant. Use the left hand to palpate the angle of the mandible on the left. Next, slide the vertical support arm inward towards the patient's jaw until the mandible cup is posterior to the angle of the mandible, then lift the arm up until the mandible cup firmly cradles the angle of the mandible.

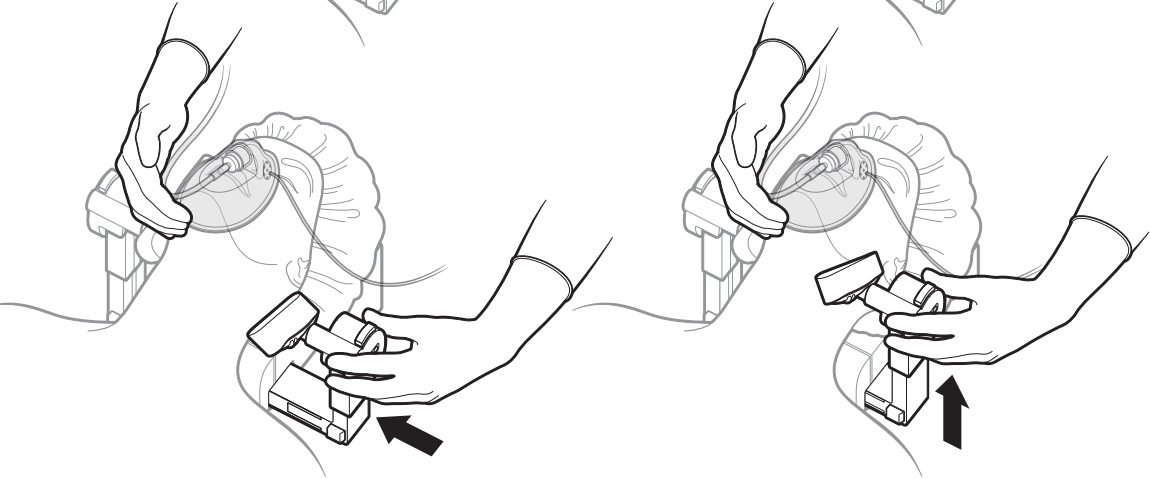

7. Using both hands, turn the left and right rotating knobs backward simultaneously so that the mandible cups tilt the patient's head back and the airway is open as evident by chest excursion and/or expired CO² waveform.

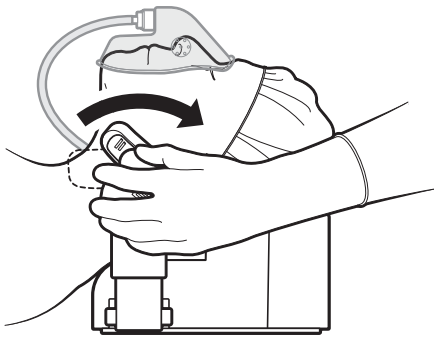

BUTTONS (A) ON TOP OF THE ROTATING KNOBS CAN NOW BE USED TO LOWER OR ROTATE THE ARMS DURING STEP 8.

8. To maximally open the airway and dissipate pressure on the mandible, the center of the mandible cups should be against the angle of the mandible. If necessary, adjust the position of the head support or vertical support arms so the mandible cups cradle the angle of the mandibles and the airway is open as evident by chest excursion, expired CO² waveform, and absence of stridor or snoring.

9. When using the JED™ with a capnograph, one can secure the CO² sampling line by pressing the tubing into the channel located on either left or right mandible cup.

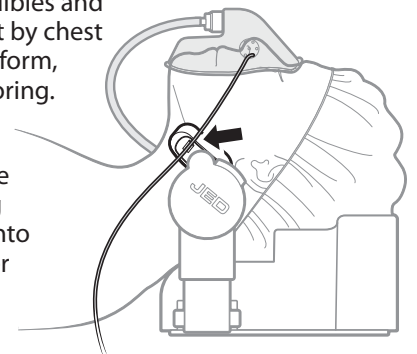

10. To remove the vertical support arms, squeeze the two buttons at the bottom of the vertical support arms and pull outward to remove them from the head support. **Remove and discard the disposable mandible cups.**

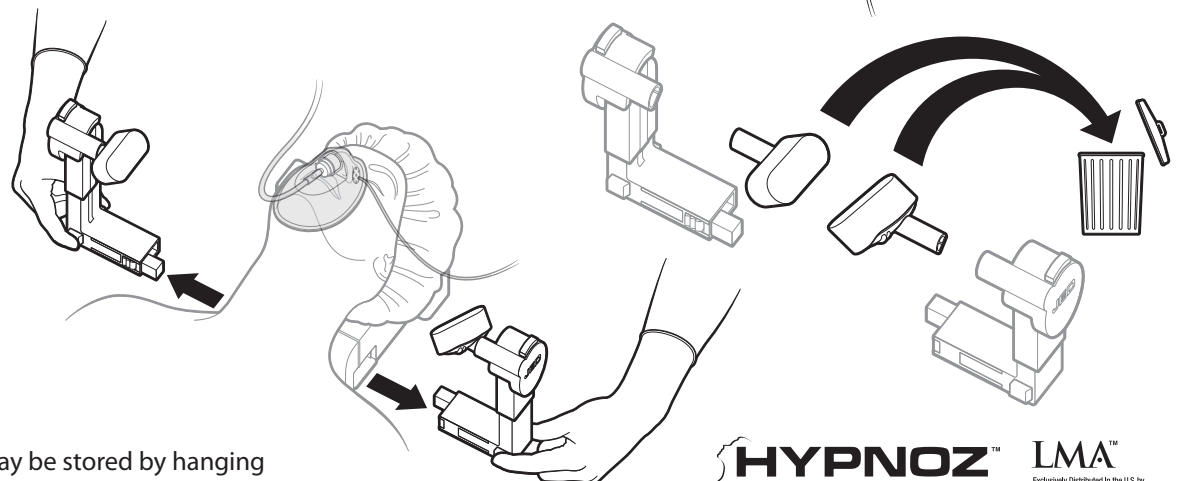

Note: The reusable JED™ may be stored by hanging it from the hole on the back of the head support.